

PARÇA KODU PART CODE	PARÇA ADI PART NAME	s ÖLÇÜSÜ (KALINLIK) s MEASURE (THICKNESS)	Malzeme Material	Kaplama / Coating		
				SN	AG	Nİ
TŞ 2489.60 DP	2.5 NO 2.TERMİNAL Ø3.7 =DP=	0.60±0.05	(CuZn30) Pirinç / Brass	-	-	-
TŞ 2489.60 RP	2.5 NO 2.TERMİNAL Ø3.7 =RP=	0.60±0.05	(CuZn30) Pirinç / Brass	-	-	-
TŞ 2489.60 RPK	2.5 NO 2.TERMİNAL Ø3.7 =RPK=	0.60±0.05	(CuZn30) Pirinç / Brass	+	-	-
TŞ 2489.60 DPK	2.5 NO 2.TERMİNAL Ø3.7 =DPK=	0.60±0.05	(CuZn30) Pirinç / Brass	+	-	-
TŞ 2489.80 DP	2.5 NO 2.TERMİNAL Ø3.7 =DP=	0.80±0.05	(CuZn30) Pirinç / Brass	-	-	-
TŞ 2489.80 RP	2.5 NO 2.TERMİNAL Ø3.7 =RP=	0.80±0.05	(CuZn30) Pirinç / Brass	-	-	-
TŞ 2489.80 RPK	2.5 NO 2.TERMİNAL Ø3.7 =RPK=	0.80±0.05	(CuZn30) Pirinç / Brass	+	-	-
TŞ 2489.80 DPK	2.5 NO 2.TERMİNAL Ø3.7 =DPK=	0.80±0.05	(CuZn30) Pirinç / Brass	+	-	-

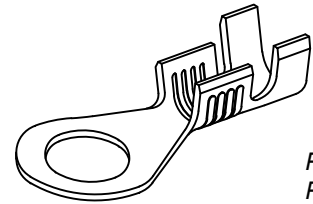
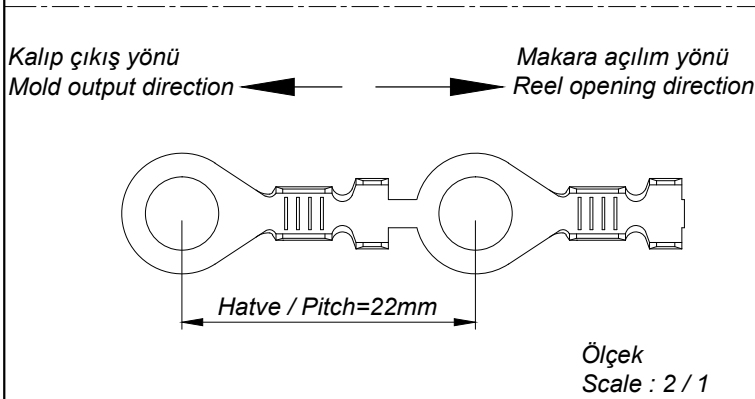
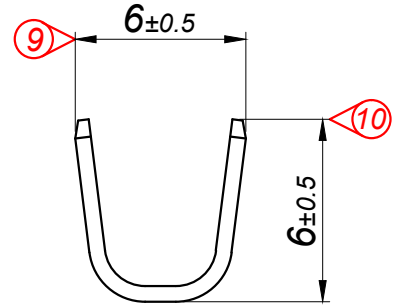
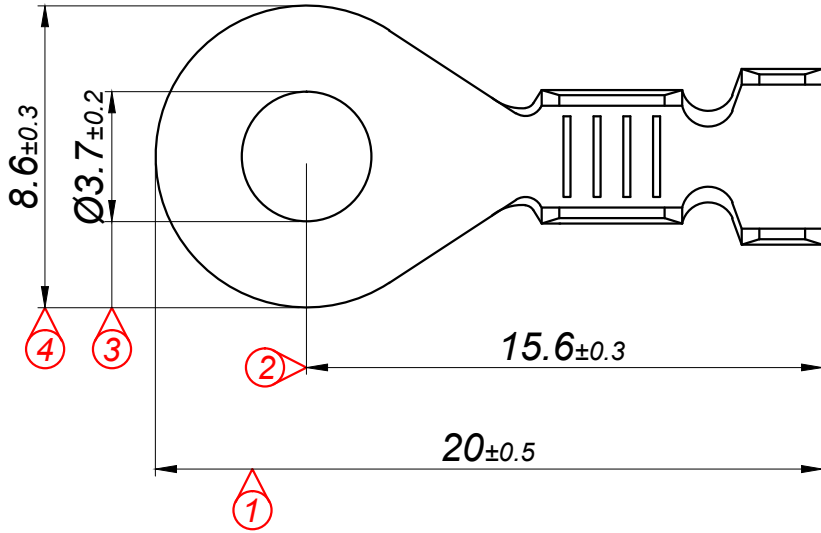
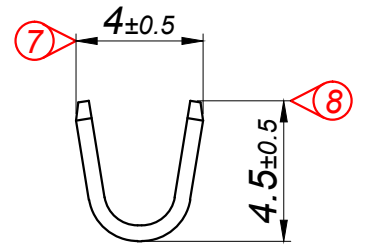
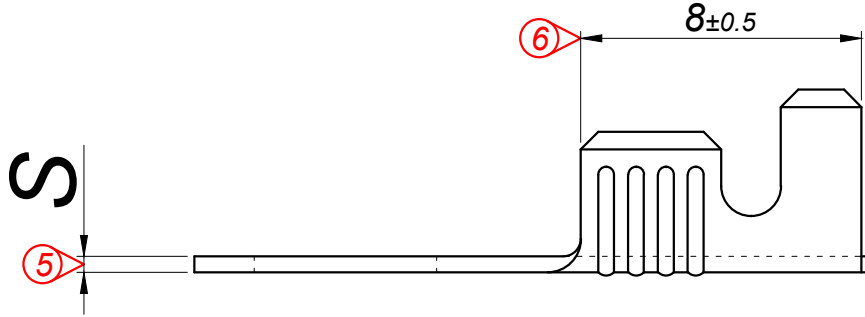

Kablo Kesiti
Wire Section : 1 - 2.50 mm²

Resim üzerinden ölçü almayınız
do not measure on drawing

Tarih / Date	18.05.2016	İmza / Signature	Ölçek / Scale		
Çizen / Desing	T.Topçu		5 / 1		
Onay / Approval	S.Gölcük		No	Değişiklik / Revision	Tarih/Date
	Parça Adı: Part Name	2.5 NO 2.TERMİNAL Ø3.7			Parça Kodu: Part Code
					TŞ 2489



Parça Adı:
Part Name

2.5 NO 2.TERMİNAL Ø3.7

Parça Kodu:
Part Code

TŞ 2489